

ATS-MS 420S

Banding Machine



ATS

Innovative Banding

2 ATS-MS 420S Banderoliermaschine ATS-MS 420S Banding machine

Die Banderoliermaschine für empfindliche Produkte banderoliert bis Format A3 (420 mm). Das Tischmodell ATS-MS 420S ist sofort betriebsbereit und braucht keine Aufheizzeit.

- Bedienungs- und servicefreundlich
- Kurzer Vordertisch für kleine Formate
- Heat seal-Aggregat für Papier- und Folienbänder
- Mikroprozessor-Steuerung CE-konform

The banding machine for sensitive products bands up to size A3 (420 mm). The table top model ATS-MS 420S starts immediately and needs no warm-up time.

- Easy operation and user friendly
- Short front table for small formats
- Heat seal-unit for paper and film band
- Microprocessor controlled, CE-approved



CE Standard

ATS-MS Jumbo-Abroller

Der Jumbo-Abroller ermöglicht Ihnen weniger Rollenwechsel und angenehmes Arbeiten mittels Höhenverstellung.

- Einfacher Standortwechsel dank Stop-Rollen
- Einsparungen bei den Materialkosten
- Variante 1: mit Höhenverstellung
- Variante 2: mit Höhenverstellung über Getriebe und Handkurbel (Bild links)

ATS-MS Jumbo-Dispenser

The Jumbo-Dispenser permits fewer roll changes and convenient operating by means of height adjustment.

- Allows for mobility
- Material cost savings
- Option 1: with adjustable height for stand
- Option 2: with adjustable height for stand through gear and hand crank (picture on left)



Option

Optional vereinfacht ein Rüsttisch am Jumbo-Abroller das Produkt-Handling.

Option

An optional set-up table on the Jumbo-Dispenser facilitates product handling.

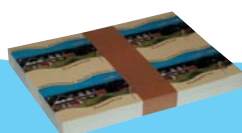

Technische Daten

Technical Data

Bogengrösse B x H / Arch size W x H	420 x 210 mm
Produktbreite / Product width	30 – 420 mm
Produktgröße / Product height	1 – 200 mm
Bandbreite / Band width	20*, 30, 50* mm
Leistung / Performance	26 Produkte/min. / products/min.
Bandspannung / Tension control	einstellbar / adjustable
Stromanschluss / Voltage	230 V/50 Hz, 115 V/60 Hz
Leistungsaufnahme / Electrical Power	ca. 0.2 kW
Gewicht / Weight	32 kg

* neu / new



Das einfache Einlegen der Rolle und Einfädeln des Bandes unterstreichen die hohe Bedienungs-freundlichkeit der ATS-MS 420S.

Simple roll placing and band feeding further enhance the high user-friendliness of the ATS-MS 420S.

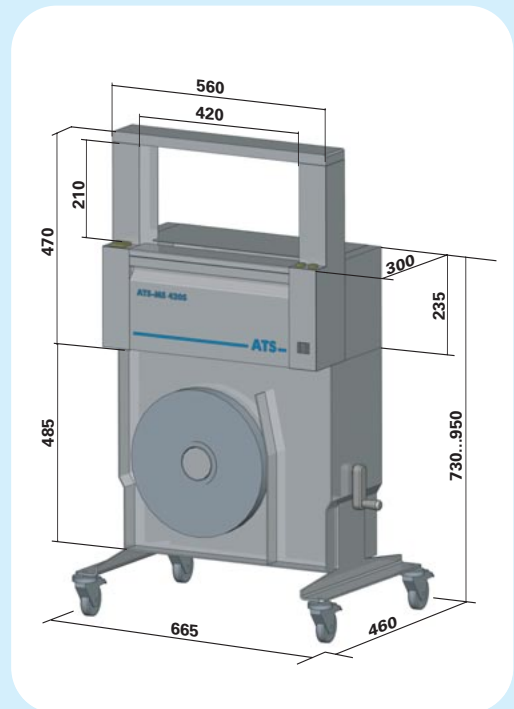

Materialtypen
 Alle Qualitäten von Papier- und Folienmaterialien können mit bis zu 6 Farben bedruckt werden.
Material types
 All qualities of paper and film materials can be imprinted with up to 6 colors.

	Beschreibung	Description
PB	Papier braun	brown paper
PW	Papier weiss	white paper
FTB	Folie transparent	transparent film



ATS-TANNER GROUP

Switzerland

ATS AUTOMATIC TAPING SYSTEMS AG

Bahnhofstrasse 21
CH-6300 Zug
Phone +41 41 710 06 03
Fax +41 41 710 81 38
www.atsag.ch, info@atsag.ch

TANNER & CO. AG Verpackungstechnik

Industriestrasse 3
CH-5616 Meisterschwanden
Phone +41 56 676 67 67
Fax +41 56 676 67 68
www.tannerag.ch, info@tannerag.ch

Benelux

ATS-TANNER BANDING SYSTEMS B.V.

Operetteweg 8
NL-1323 VA Almere
Phone +31 36 546 95 75
Fax +31 36 546 95 76
www.ats-tanner.nl, info@ats-tanner.nl

Canada

ATS-TANNER BANDING SYSTEMS INC.

1234 Old Carriage Way
Oakville ON L6M 2E3 (Canada)
Phone +1 905 815 9999
Fax +1 905 815 0443
www.ats-tanner.ca, info@ats-tanner.ca

Germany

ATS-TANNER GMBH Banderoliersysteme

Friedrich-Ebert-Strasse
DE-51429 Bergisch Gladbach
Phone +49 2204 84 34 60
Fax +49 2204 84 34 61
www.ats-tanner.de, info@ats-tanner.de

Spain

ATS-TANNER SISTEMAS DE ENFAJADO S.A.

Polígono Leizotz, Parcela I, Nave 7
ES-20140 Andoain (Guipúzcoa)
Phone +34 943 303023
Fax +34 943 303021
www.ats-tanner.es, info@ats-tanner.es



Ausstellungsraum von 300 m²
300 m² showroom



Verkaufs- und Servicecenter (VSC)
Sales and service centre



Logistik- und Produktionscenter (LPC)
Logistics and production centre

ATS ist auf allen 5 Kontinenten vertreten.
ATS is represented on all 5 continents.